



# SANDWICH PANEL INDUSTRY ASSEMBLY SOLUTIONS

BUILDING TRUST



# ADHESIVE SOLUTIONS FOR THE SANDWICH PANEL INDUSTRY

Sika's technologies are suitable to bond the most common substrates used in industrial applications. For years, manufacturers of sandwich panels have been relying on Sika for the bonding of laminated decoration sheet to the core panel with automated process as well as the edge of off-standard products with manual application. SikaForce® and SikaMelt® wide range of solutions fully meets these requirements with cost-optimization and durable results.

## ADVANTAGES

- Full range offer from Sika to meet customer process needs
- Fully automated laminating process possible
- Solvent-free solutions
- Room temperature cure with SikaForce® technology

## PRODUCT FEATURES

- Suitable for a wide range of substrates
- Optimized for large and small scale industrial applications
- Fast handling properties with high green strength of SikaMelt®-9670
- Excellent heat and aging resistance after moisture curing with SikaMelt®-9670
- SikaForce®-7710 L35 approved according to IMO Res. A.653(16)
- Long open time / short press time with SikaForce®-7710 L35

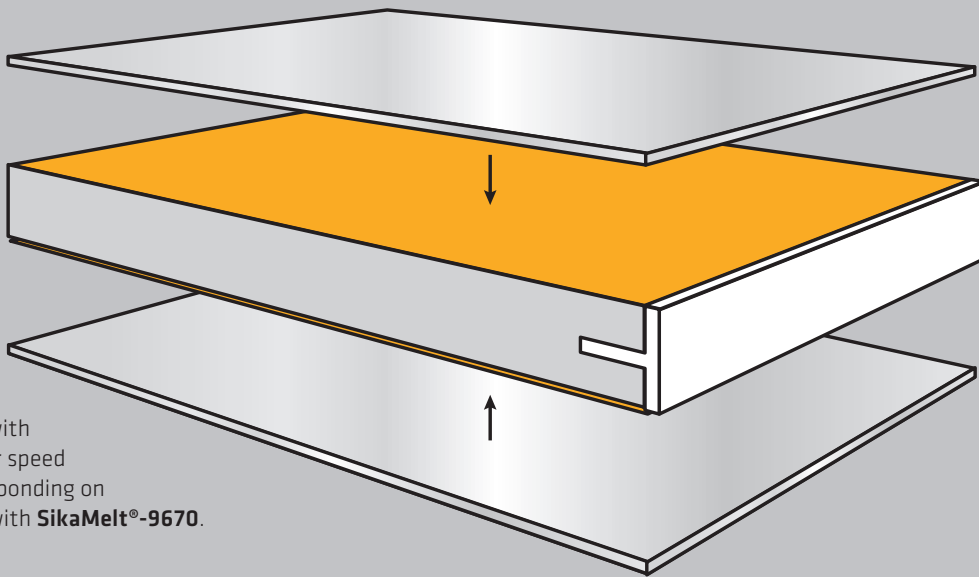

Sheet bonding on core with **SikaForce®-7710 L35** for speed assembly. Manual edge bonding on off-standard products with **SikaMelt®-9670**.

## SIKA SERVICES AG

Tueffenwies 16  
CH-8048 Zurich  
Phone: +41 (0) 58 436 40 40  
Fax: +41 (0) 58 436 55 30  
www.sika.com/appliances

Our most current General Sales Conditions shall apply.  
Please consult the Data Sheet prior to any use and processing.



**BUILDING TRUST**

