



SikaRoof® CONTROL – MONITORING / LEAK DETECTION SYSTEMS

THE SMART FLAT ROOF

BUILDING TRUST



TABLE OF CONTENTS

03	General System Information / Overview
04	Control Pipe Manual – Visual Inspection Possibility
05	Control Pipe with Integrated 24/7 Monitoring
06	Control Pipe and Integrated Leak Detection Possibility
07	Control Pipe with Integrated 24/7 Monitoring and Leak Detection Possibility
08	Roof / Terrace Version with Integrated 24/7 Monitoring
09	Roof / Terrace Version with Integrated 24/7 Monitoring and Leak Detection Possibility
10	System for Limiting the Area of Water Spread Inside the Roof
11	System for Permanent 24/7 Roof Monitoring
12	System for Precise Leak Detection – Terrace Control / Monitoring System
13	System for Precise Leak Detection – Roof Control / Monitoring System
14	Leak Detection with Low Voltage
15	Leak Detection with High Voltage
16	Product Portfolio

SikaRoof® CONTROL SYSTEMS

GENERAL SYSTEM INFORMATION / OVERVIEW

ASPECTS SUCH AS SUSTAINABILITY AND ENERGY EFFICIENCY are becoming increasingly important in today's world. This development is based on a holistic view of a building in its entire life cycle. SikaRoof® Control Systems enables to inspect water ingress and detect / locate the defective area and helps to secure material assets and prevents consequential damages. The continuous monitoring of the building condition allows for a targeted and cost-effective maintenance. The SikaRoof® Control – Monitoring / Leak Detection Systems are designed as modular systems.

	Control Pipe manual visual inspection possibility	Control Pipe with integrated 24/7 monitoring	Compartment / Waterstop System	SikaRoof® Control (precise leak detection)
Detection of water on vapour- control layer / barrier	● (visual check / passive)	● (monitoring / active)	○	○
Limiting the area of water spread inside the roof build-up	○	○	● (100 – 600 m ² compartment size)	○
Precise leak detection possibility	○	○	○	● (high / low voltage test)

● Suitable
○ Not suitable



SikaRoof® CONTROL

CONTROL PIPE MANUAL - VISUAL INSPECTION POSSIBILITY

Enables inspecting any water ingress by visually inspecting the control pipe on the roof. The roof area is usually divided into compartments.

- 1 Vapour- control layer / barrier
- 2 SikaRoof® Control Pipe
- 3 Thermal insulation
- 4 FPO or PVC membrane
- 5 FPO or PVC Pipe Flashing 110
- 6 Insulation plug with cap

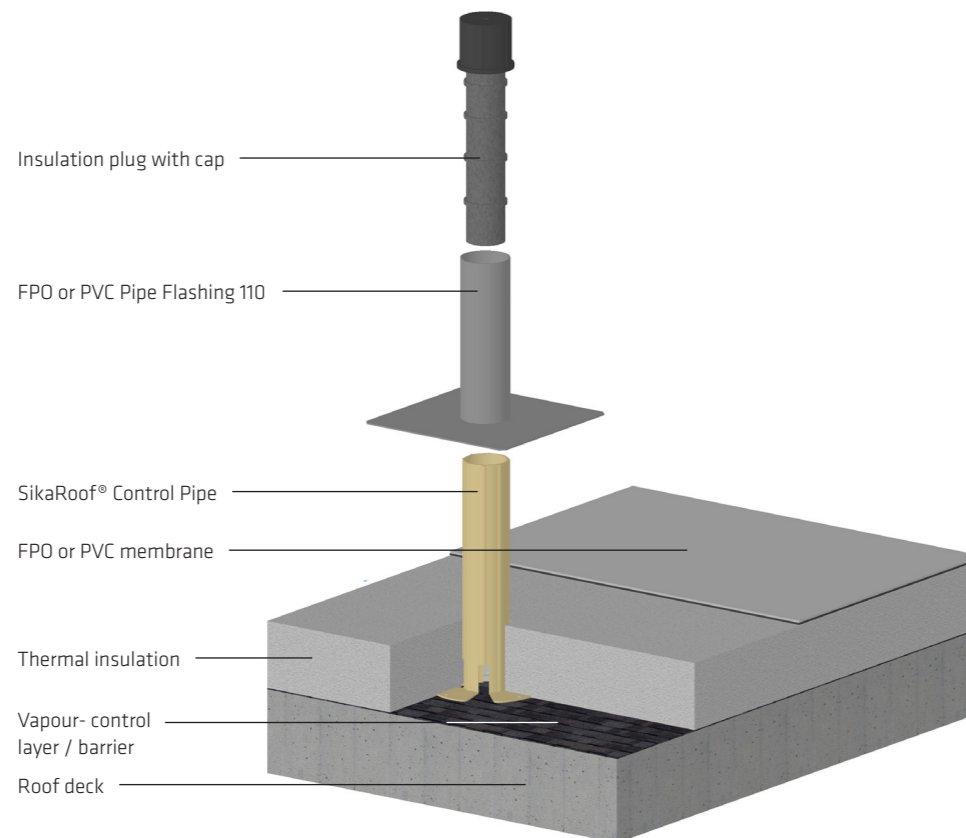
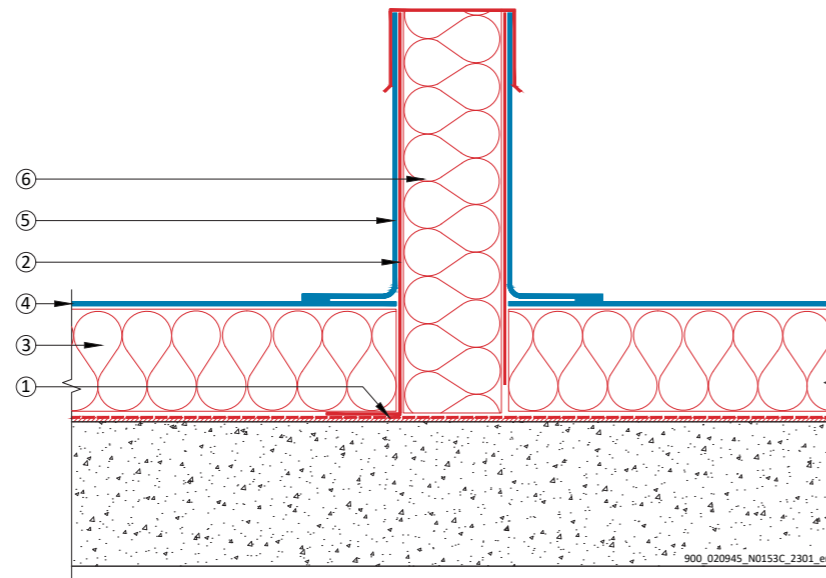

SikaRoof® MONITORING

CONTROL PIPE WITH INTEGRATED 24/7 MONITORING

Permanent electronic roof monitoring in the control pipe with SikaRoof® Sensor Active R. The roof area is usually divided into compartments.

- 1 Vapour- control layer / barrier
- 2 SikaRoof® Control Pipe
- 3 Thermal insulation
- 4 FPO or PVC membrane
- 5 FPO or PVC Pipe Flashing 110
- 6 Sensor insulation plug with cap
- 7 SikaRoof® Sensor Active R

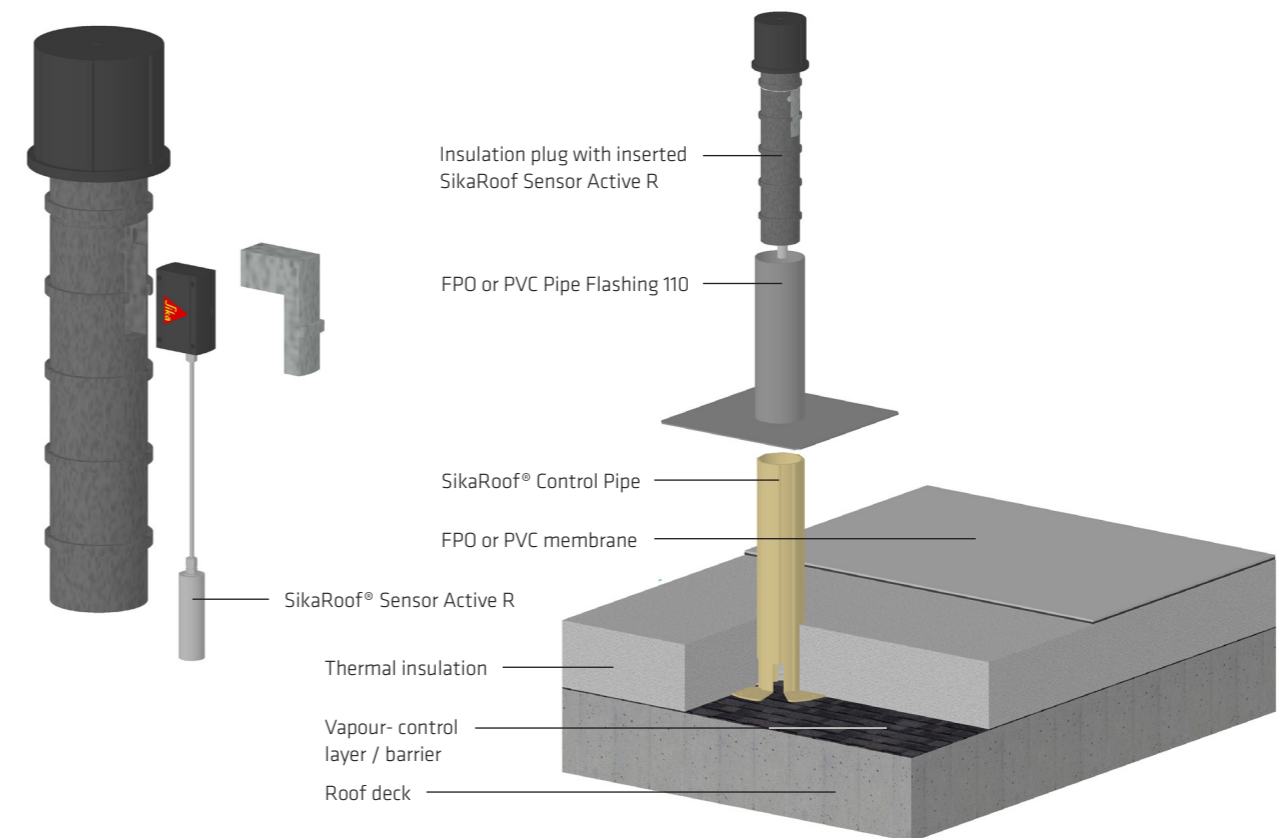
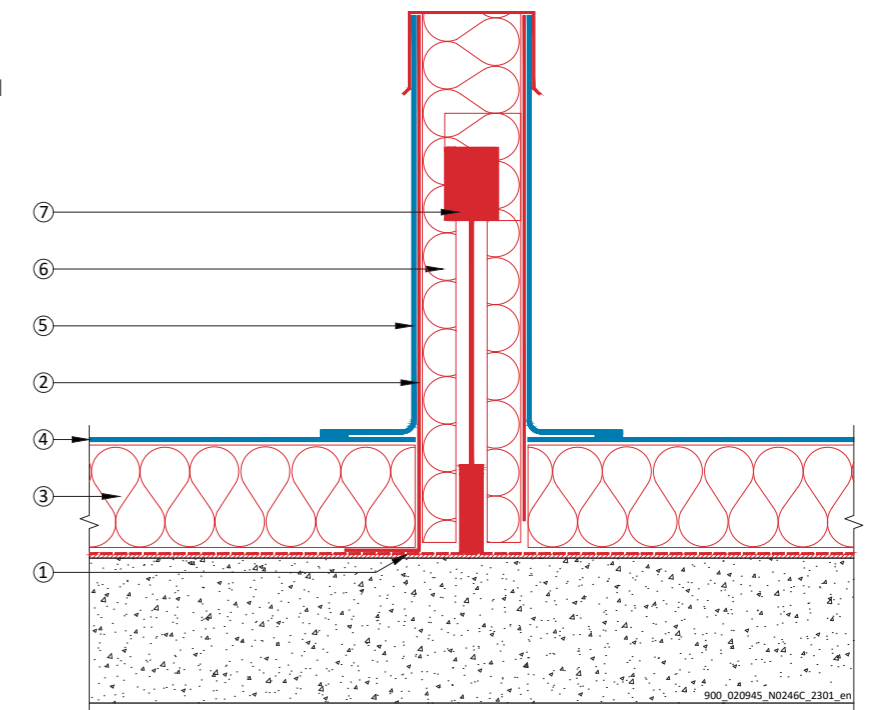

SikaRoof® CONTROL

CONTROL PIPE AND INTEGRATED LEAK DETECTION POSSIBILITY

Enables inspecting any water ingress by visually inspecting the control pipe on the roof and precise leak detection possibility.

- 1 Vapour- control layer / barrier
- 2 SikaRoof® Control Pipe
- 3 Thermal insulation
- 4 SikaRoof® Glass - Graphite Fleece
- 5 SikaRoof® Control Contact Plate
- 6 FPO or PVC membrane
- 7 FPO or PVC Pipe Flashing 110
- 8 Insulation plug with cap

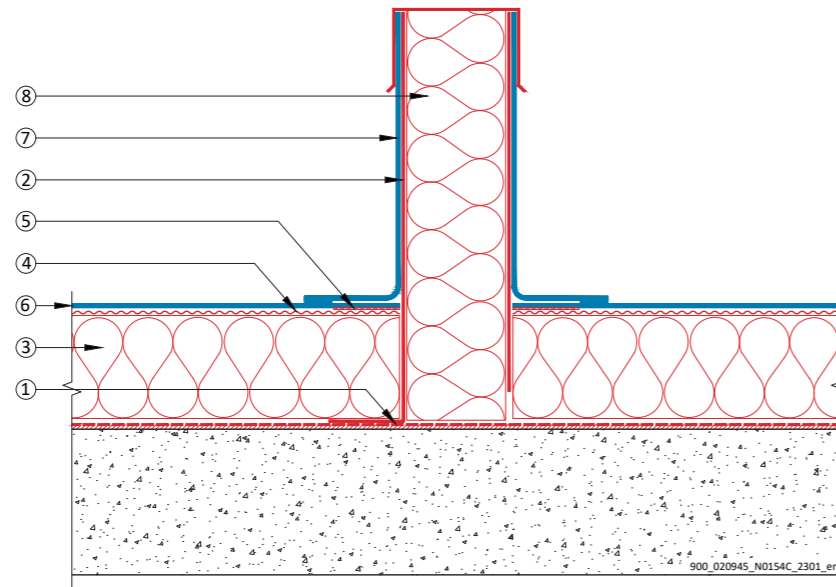

SikaRoof® CONTROL - MONITORING

CONTROL PIPE WITH INTEGRATED 24/7 MONITORING AND LEAK DETECTION POSSIBILITY

Permanent electronic roof monitoring in the control pipe with SikaRoof® Sensor Active R. The roof area is usually divided into compartments.

- 1 Vapour- control layer / barrier
- 2 SikaRoof® Control Pipe
- 3 Thermal insulation
- 4 SikaRoof® Glass - Graphite Fleece
- 5 SikaRoof® Control Contact Plate
- 6 FPO or PVC membrane
- 7 FPO or PVC Pipe Flashing 110
- 8 Sensor insulation plug with cap
- 9 SikaRoof® Sensor Active R

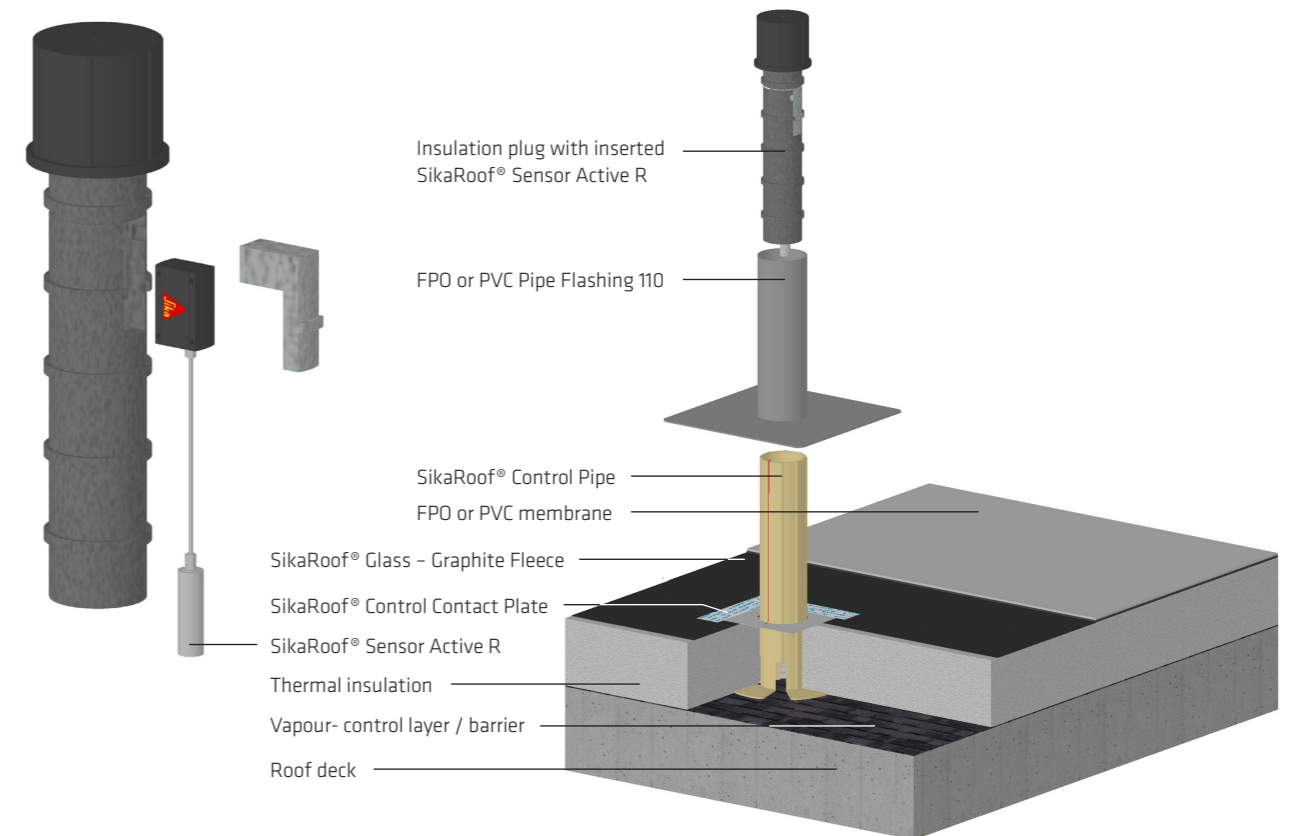
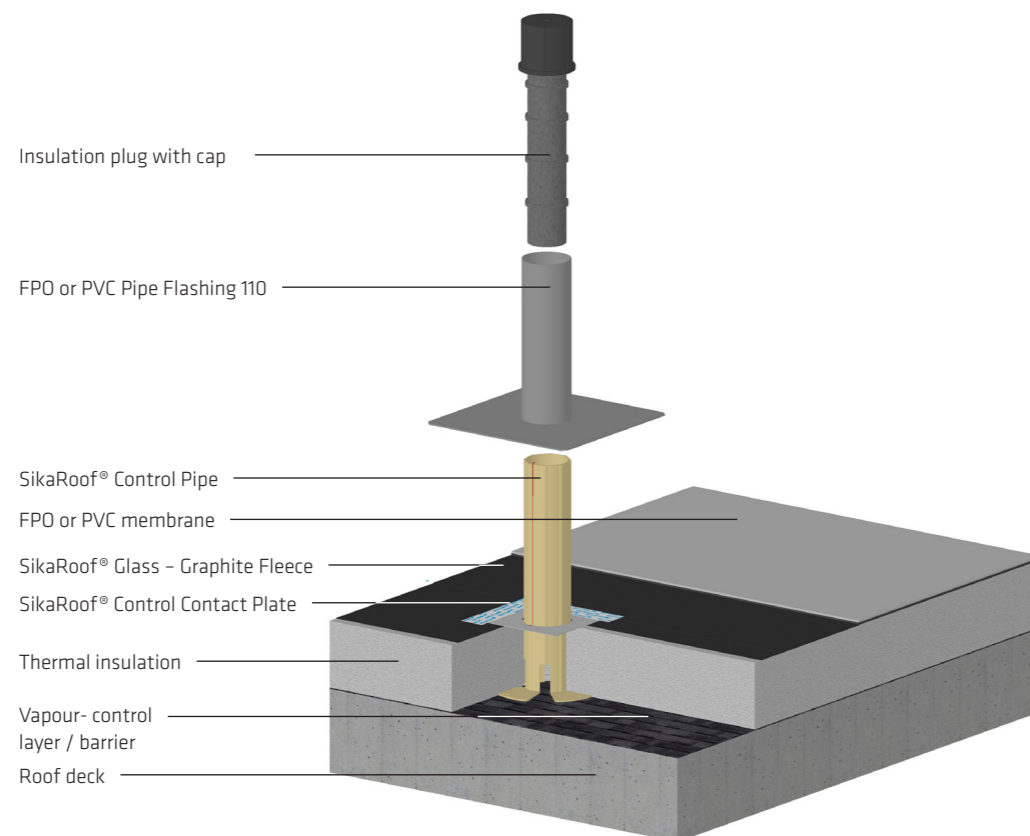
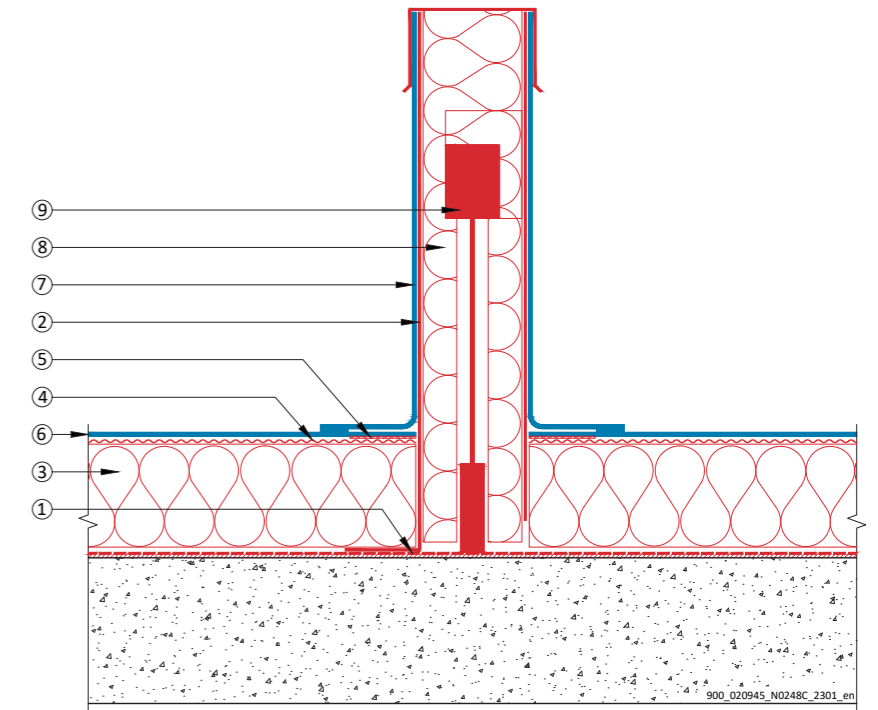

SikaRoof® TERRACE MONITORING

ROOF / TERRACE VERSION WITH INTEGRATED 24/7 MONITORING

Permanent electronic roof monitoring in the SikaRoof® XPS insulation core with SikaRoof® Sensor Active T. The roof area is usually divided into compartments.

- 1 Vapour- control layer / barrier
- 2 FPO or PVC roof drain
- 3 Thermal insulation
- 4 FPO or PVC membrane
- 5 Lid with rubber seal
- 6 SikaRoof® XPS insulation core
- 7 SikaRoof® Sensor Active T

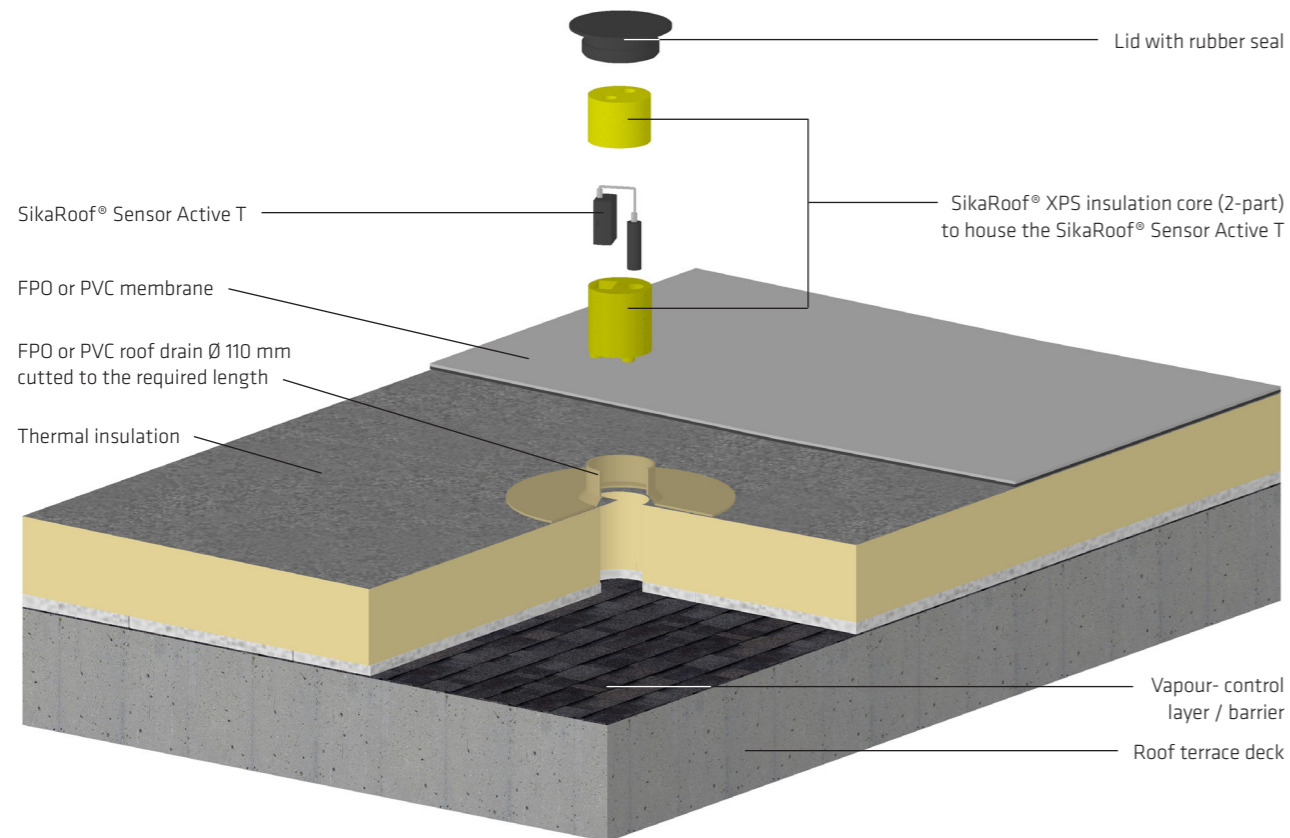
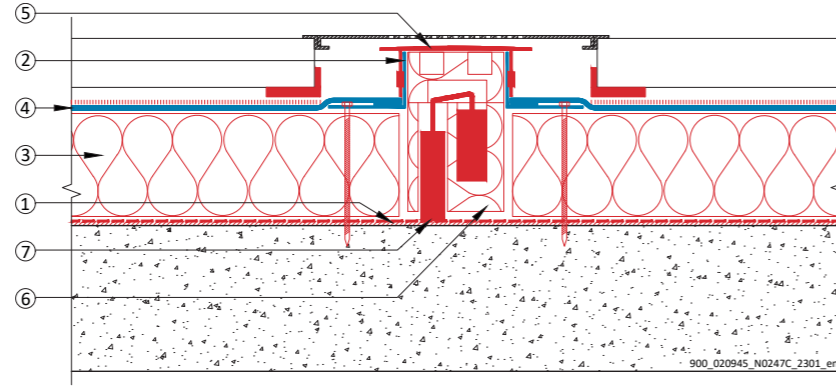

SikaRoof® TERRACE MONITORING

ROOF / TERRACE VERSION WITH INTEGRATED 24/7 MONITORING AND LEAK DETECTION POSSIBILITY

Permanent electronic roof monitoring in the SikaRoof® XPS insulation core with SikaRoof® Sensor Active T and precise leak detection possibility

- 1 Vapour- control layer / barrier
- 2 FPO or PVC roof drain
- 3 Thermal insulation
- 4 SikaRoof® Glass - Graphite Fleece
- 5 SikaRoof® Control Contact Plate
- 6 FPO or PVC membrane
- 7 Lid with rubber seal
- 8 SikaRoof® XPS insulation core
- 9 SikaRoof® Sensor Active T

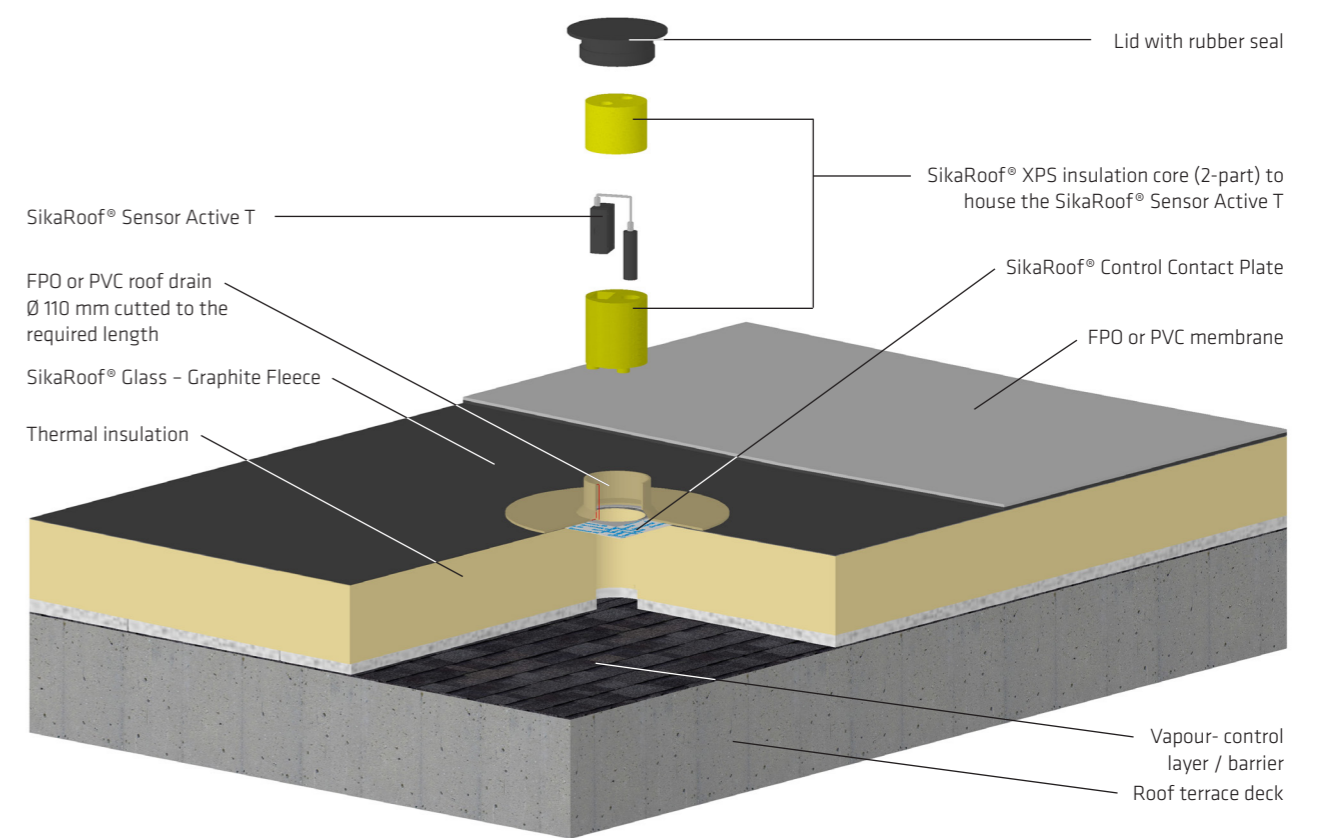
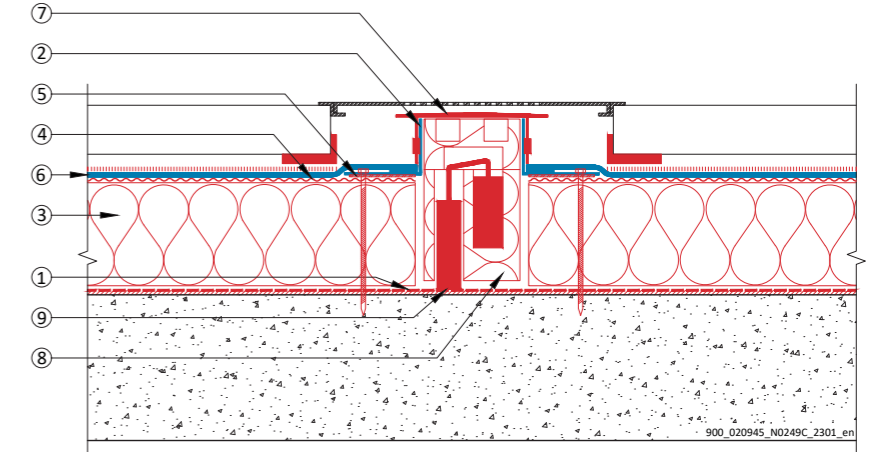

COMPARTMENT / WATERSTOP SYSTEM

SYSTEM FOR LIMITING THE AREA OF WATER SPREAD INSIDE THE ROOF

ROOF COMPARTMENTS WITH THE WATERSTOP SYSTEM

To achieve a compartment system, the roof area shall be divided into smaller areas of 100 m² up to 600 m², in order to limit the leaking area when the roof ever becomes damaged. The compartment is executed with the waterstop system.

The design and layout of the compartment system should be co-ordinated with roof valleys and the drainage system. Waterstops are typically positioned at high points and the control pipe at the low point of the roof. Each compartment needs to be provided with a control pipe.

Waterstops form a watertight seal between the roofing membrane and the vapour-control layer / barrier in order to minimize water damage in case of a leak. Waterstops are important safety components. Besides subdividing roofs into smaller areas, they separate special zones from the rest of the roof. Waterstops are installed to divide the roof into compartments.

Compartment size:

- 100 to 300 m² (if the protective layer is difficult to remove)
- 300 to 600 m² (if the protective layer is easy to remove)

- 1 Compartment
- 2 Waterstop
- 3 Valley
- 4 Control pipe
- 5 Roof drain

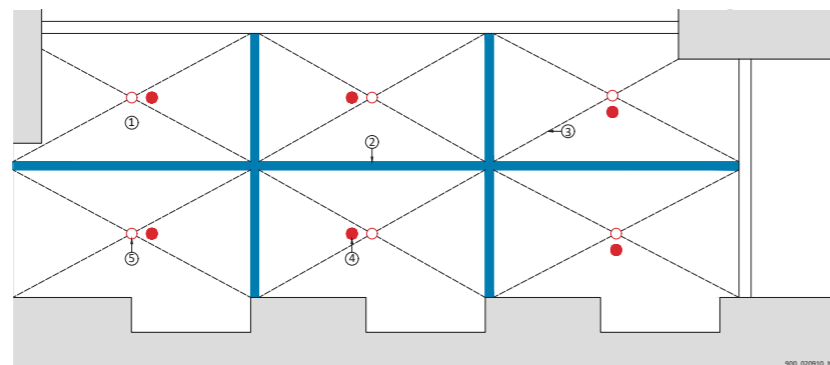

- 1 Roof deck
- 2 Bituminous vapour barrier, fully adhered at least in the area of partition
- 3 Thermal insulation layer - edge cut at 45° - adhered to serve as a stopper for the partition
- 4 Sarnafil® T membrane adhered with hot bitumen to the vapour barrier
- 5 Loose laid thermal insulation layer - edge cut a 45°
- 6 Sarnafil® T membrane welded to the already installed membrane

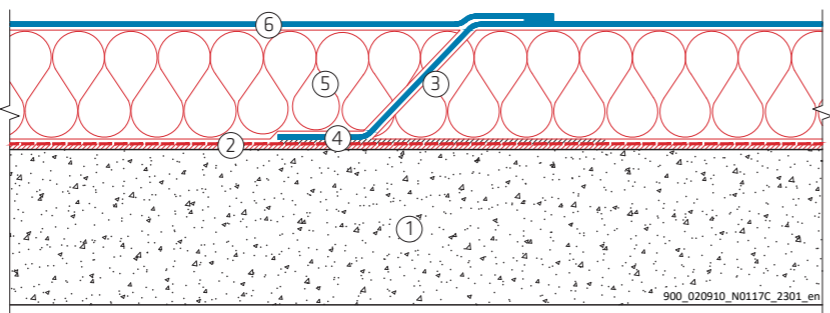
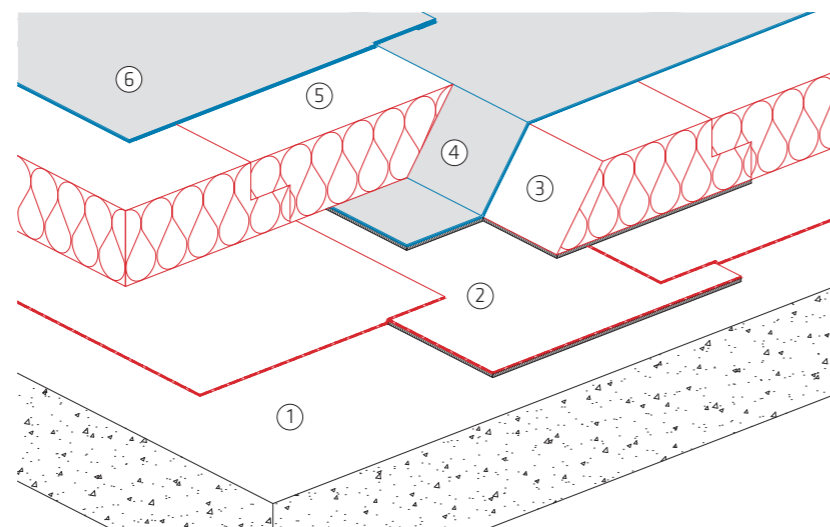

SikaRoof® MONITORING

SYSTEM FOR PERMANENT 24/7 ROOF MONITORING

SYSTEM FOR PERMANENT 24/7 ROOF MONITORING

- Radio based sensor system based on latest IoT-Technology
- One Sensor covers up to 300 m² roof area
- Sensors are very easy accessible at any time after installation
- Plug and play system - installed by the roofing contractor
- Suitable also for retrofitting on existing flat roofs
- Self-sufficient electric power supply with long life batteries
- Detects liquid water on the vapour-control layer / barrier
- Monitors the relative humidity inside the roof build-up
- In case of roof damage - informs the building owner and or roofing contractor via Email



MONITORING APP

Easy, informative and intuitive. The monitoring App can be used on computers and smartphones and provides you real time data 24/7.

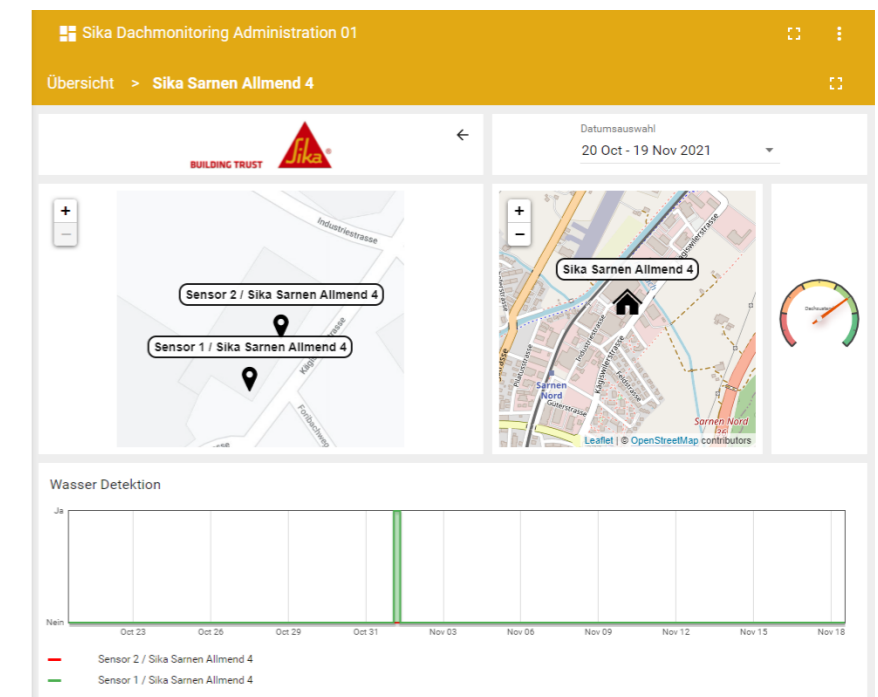

SikaRoof® CONTROL

SYSTEM FOR PRECISE LEAK DETECTION -
TERRACE CONTROL / MONITORING SYSTEM

The System is suitable for new construction and refurbishment projects. In the construction phase of the roof, the electrically conductive special glass/graphite fleece is installed below the roofing membrane on top of the thermal insulation. In order to carry out leak detection, two Control Pipes together with the stainless steel contact plate are installed every 1500m². This gives an easy access point to the technician to connect the leak Detection device.

MAIN ADVANTAGES OF THE SYSTEM

- Possibility of simple leak-tests from the beginning
- Leak detection/tests can be conducted with the Low and high voltage method
- Significant reduced costs due to target determination of the error sources

TERRACE CONTROL / MONITORING SYSTEM (cut model)

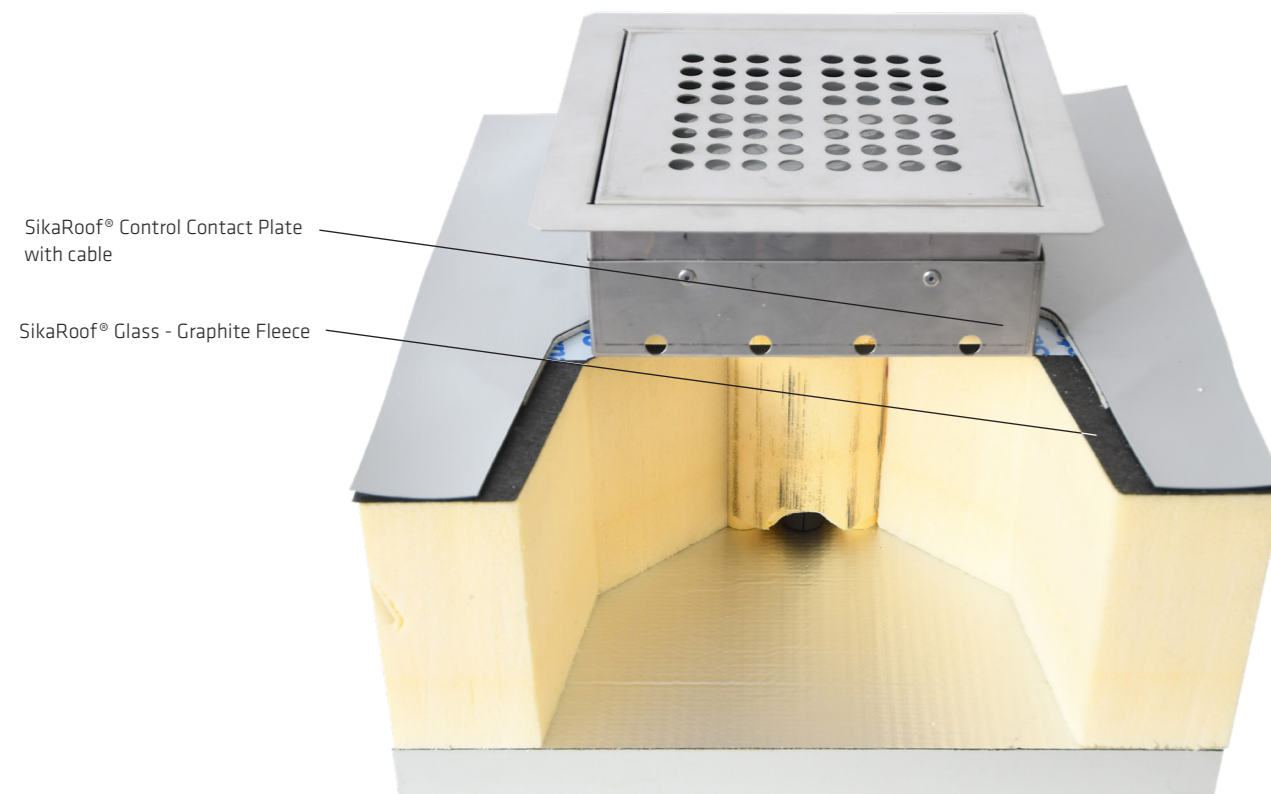

SikaRoof® CONTROL

SYSTEM FOR PRECISE LEAK DETECTION -
ROOF CONTROL / MONITORING SYSTEM

ROOF CONTROL / MONITORING SYSTEM (cut model)

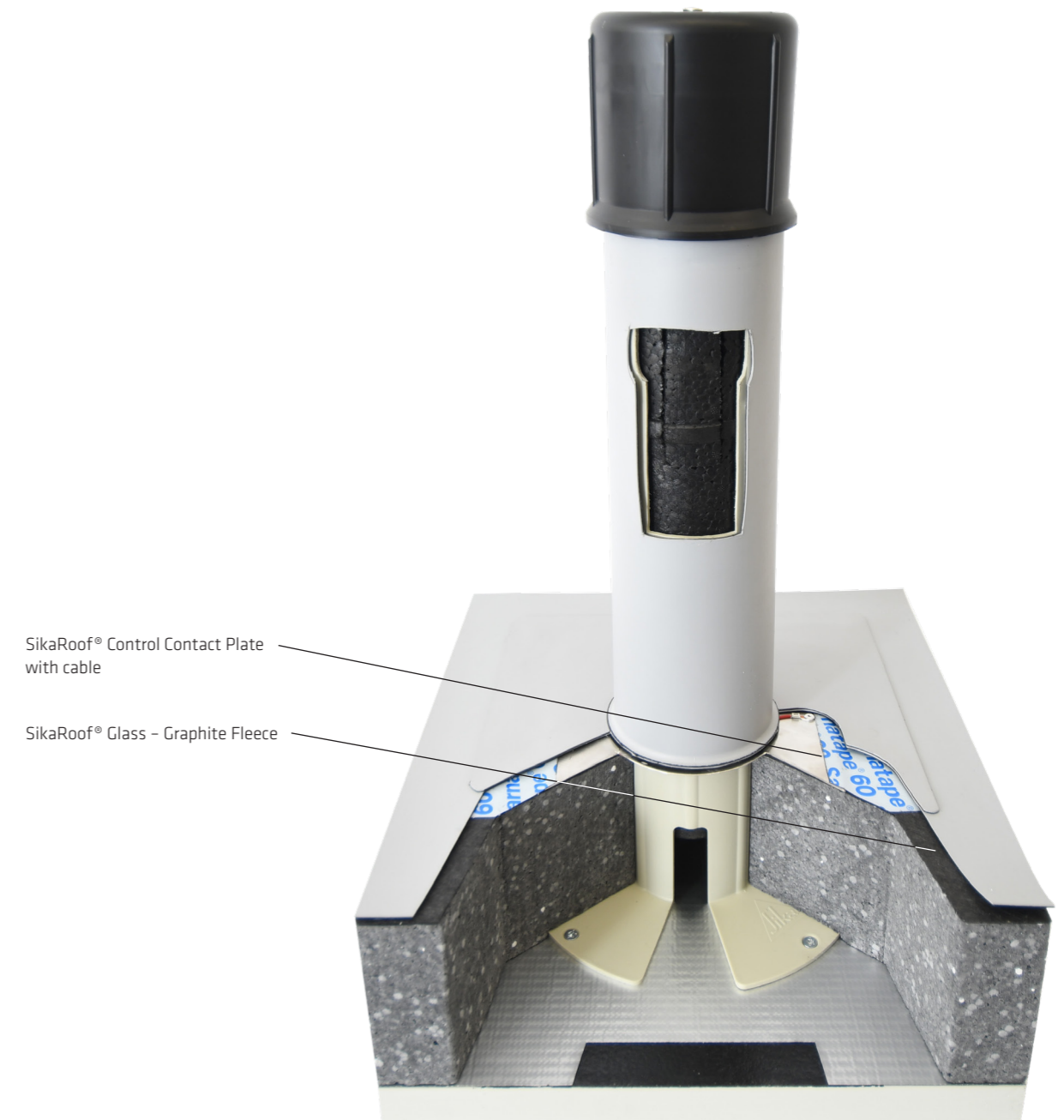

SikaRoof® LEAK DETECTION

LEAK DETECTION WITH LOW VOLTAGE



Low voltage leak detection requires only a thin film of water on the tested surface. The negative output of the generator is applied to the trace wire which borders the test area, whilst the positive output is connected to a suitable building substrate. If water has penetrated the roofing membrane within the test area, a current will flow from this source point, via the water on the roof towards the trace wire. The detector is used to identify the direction of electrical current and detect the point of origin (where water is penetrating the roofing membrane).

Note: The roof layers above the Roofing Membrane must be water-permeable. An electrically conductive layer is required below the roofing membrane.

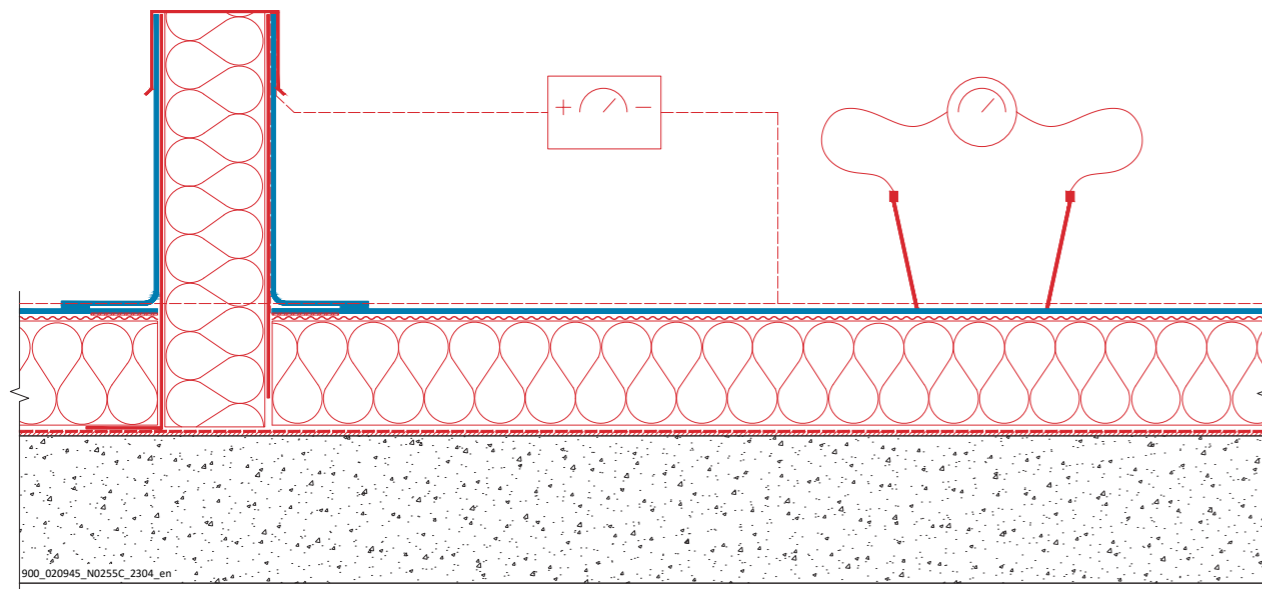

SikaRoof® LEAK DETECTION

LEAK DETECTION WITH HIGH VOLTAGE



The earth lead from the high voltage test device is connected to a convenient earth point on the structure. A high voltage DC current is applied to the dry surface of the roofing membrane. When there are no faults present, the roofing membrane acts as an electrical insulator by stopping the flow of current out of the device. When the electrode passes a fault or hole, the high voltage jumps the gap between the electrode and the conductive layer below the roofing membrane, causing a current to flow. The audible and visual alarm of the testing device will alert the operator.

Note: The surface/roof membrane needs to be completely dry. An electrically conductive layer is required below the roofing membrane.

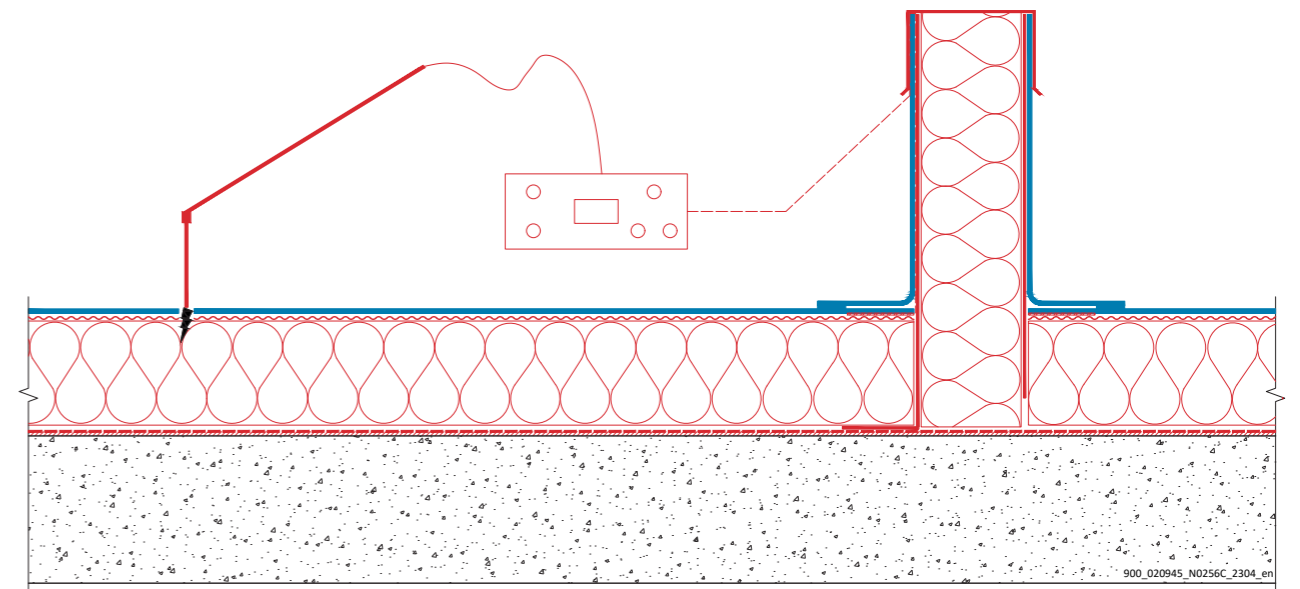

SikaRoof® CONTROL – MONITORING

PRODUCT PORTFOLIO

Control Pipe Set



DESCRIPTION

The Control Pipe Set is made of rigid high quality polypropylene (PP) pipe and cap, expanded polypropylene (EPP) insulation plug and prefabricated Sarnafil® flashing.

USES

The Control Pipe Set enables to check the watertightness of a flatroof from the rooftop.

CHARACTERISTICS / ADVANTAGES

- Resistant to UV exposure
- Ease of application

PACKAGING

The Control Pipe Set consists of:

- 1 pcs. SikaRoof® Control Pipe 110
- 1 pcs. Insulation plug with cap
- 1 pcs. Pipe flashing 110 (FPO or PVC)

Control Pipe Set for SikaRoof® Sensor R



DESCRIPTION

The Control Pipe Set for SikaRoof® Sensor R comprises of 3 parts. A rigid high quality polypropylene (PP) pipe, an expanded polypropylene (EPP) insulation plug with cap and a prefabricated Sarnafil® flashing.

USES

The Control Pipe Set may only be used by experienced professionals. The Control Pipe Set enables to house the SikaRoof® Sensor active R and provides an inspection point on the flat-rooftop to check / monitor the watertightness

CHARACTERISTICS / ADVANTAGES

- Easily installed
- Suitable for new projects and retrofitting existing flat roofs

PACKAGING

The Control Pipe Set consists of:

- 1 pcs. SikaRoof® Control Pipe 110
- 1 pcs. Insulation plug with cap
- 1 pcs. Pipe flashing 110 (FPO or PVC)

SikaRoof® XPS insulation core and Lid



DESCRIPTION

SikaRoof® XPS insulation core and Lid made of polypropylene (PP). Control Pipe Set can be upgraded with the electrically conductive SikaRoof® Glass – Graphite Fleece and the SikaRoof® Control Contact Plate to generate a leak detection system. The Insulation core is prepared to house the SikaRoof® Sensor T. The corresponding rainwater outlet (FPO / PVC) with spigot Ø 110 mm needs to be ordered separately. The spigot need to be shortened to the required length.

USES

Enables to monitor the terrace build-up in combination with SikaRoof® Sensor T.

CHARACTERISTICS / ADVANTAGES

For roof system:

- FPO
- PVC

SikaRoof® Glass – Graphite Fleece

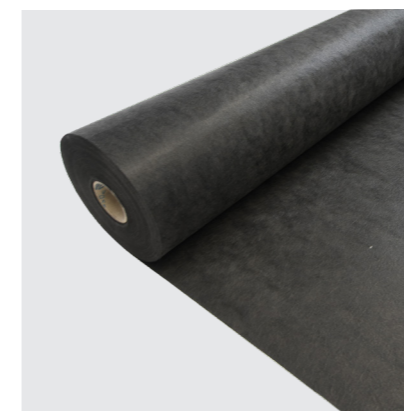

DESCRIPTION

SikaRoof® Glass – Graphite Fleece is a conductive and fire protection layer made of non-woven glass fibre. Applied in combination with ballasted and mechanically fastened roofing membranes.

USES

SikaRoof® Glass – Graphite Fleece may only be used by experienced professionals. SikaRoof® Glass – Graphite Fleece is used as a conductive layer to facilitate leak detection below Sarnafil® roofing membranes.

CHARACTERISTICS / ADVANTAGES

- Easily applied
- Suitable for mechanically fastened and ballasted roof systems

TECHNICAL INFORMATION

Roll dimension: 2 x 50 m
Weight: 120 g/m²

SikaRoof® Stainless Steel Mesh



DESCRIPTION

SikaRoof® Stainless Steel Mesh is an electrically conductive stainless steel mesh.

USES

SikaRoof® Stainless Steel Mesh may only be used by experienced professionals. SikaRoof® Stainless Steel Mesh is used as a conductive layer to facilitate leak detection below adhered Sarnafil® roofing membranes.

CHARACTERISTICS / ADVANTAGES

- Highly electrically conductive
- Easily applied
- Corrosion resistant
- Not flammable
- Suitable for adhered roof systems

TECHNICAL INFORMATION

Roll dimension: 1.50 x 40 m
Weight: 87 g/m²

SikaRoof® CONTROL – MONITORING

PRODUCT PORTFOLIO

SikaRoof® Control Contact Plate

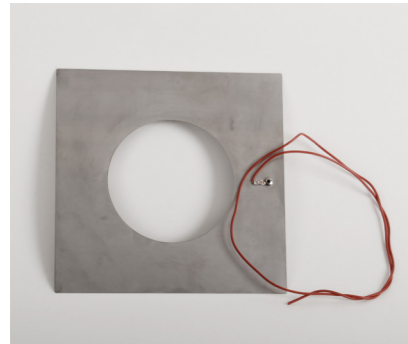

DESCRIPTION

The SikaRoof® Control Contact Plate is a stainless steel plate to connect the applied conductive glass felt with the read-out device.

USES

SikaRoof® Control Contact Plate may only be used by experienced professionals.

- Contact plate between the applied conductive glass felt and the read-out device

CHARACTERISTICS / ADVANTAGES

- Easy application without the use of fasteners
- Plate includes the the 800 mm long connection wire

SikaRoof® Sensor Active R / T



DESCRIPTION

The SikaRoof® Sensor Active R / T is a battery powered, wireless sensor for water detection and monitoring the humidity in flat roof build-up.

USES

SikaRoof® Sensor Active R / T may only be used by experienced professionals.

- SikaRoof® Sensor Active R / T is used to detect water ingress and to monitor the humidity in flat roof build-up

CHARACTERISTICS / ADVANTAGES

- Radio based sensor system based on latest IoT-Net-work technology
- Easily installed, no electrician required on job-site
- Easily to start-up due to plug-and-play system
- Self-sufficient electric power supply with batteries
- Suitable for new construction, refurbishment and retrofitting

SikaRoof® Sensor Data Transmission

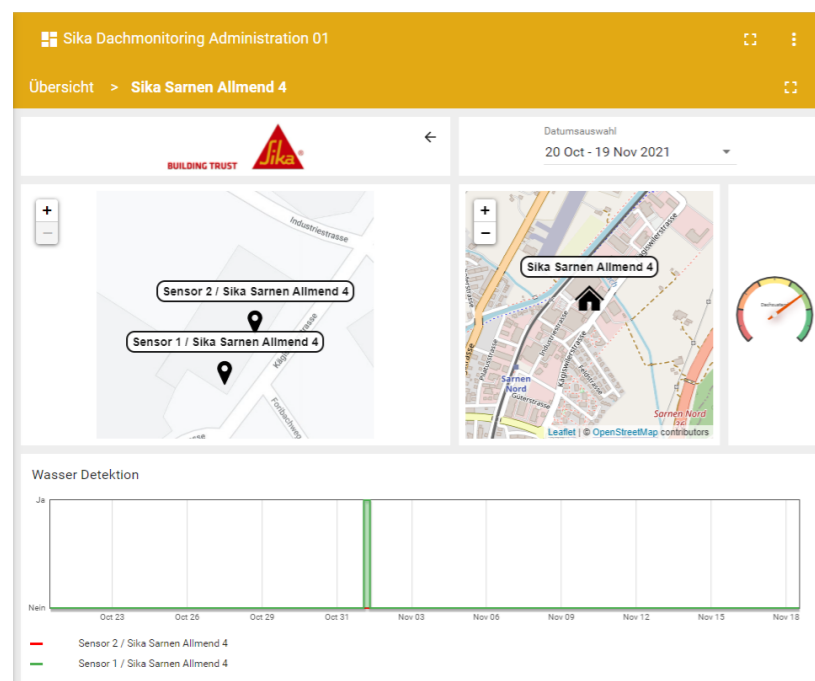

DESCRIPTION

Transmission from SikaRoof® Sensor monitored data to the Sika platform.

USES

In combination with SikaRoof® Sensor Active R / T.



Disclaimer

The information, and, in particular, the recommendations relating to the application and end-use of Sika products, are given in good faith based on Sika's current knowledge and experience of the products when properly stored, handled and applied under normal conditions in accordance with Sika's recommendations. In practice, the differences in materials, substrates and actual site conditions are such that no warranty in respect of merchantability or of fitness for a particular purpose, nor any liability arising out of any legal relationship whatsoever, can be inferred either from this information, or from any written recommendations, or from any other advice offered. The user of the product must test the product's suitability for the intended application and purpose. Sika reserves the right to change the properties of its products. The proprietary rights of third parties must be observed. All orders are accepted subject to our current terms of sale and delivery. Users must always refer to the most recent issue of the local Product Data Sheet for the product concerned, copies of which will be supplied on request.

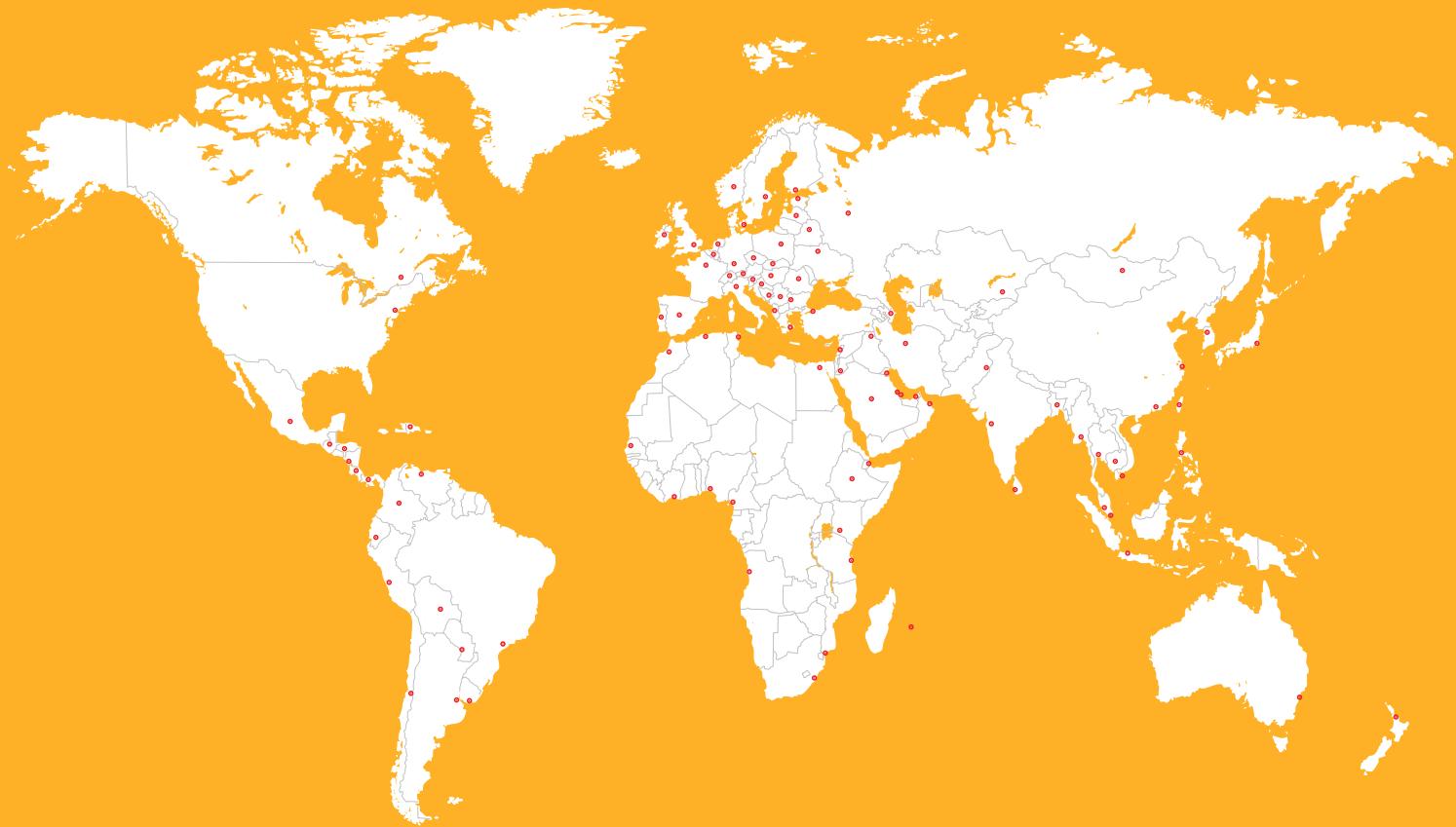

GLOBAL BUT LOCAL PARTNERSHIP

WE ARE SIKA

Sika is a specialty chemicals company with a leading position in the development and production of systems and products for bonding, sealing, damping, reinforcing and protecting in the building sector and the motor vehicle industry. Sika's product lines feature concrete admixtures, mortars, sealants and adhesives, structural strengthening systems, flooring as well as roofing and waterproofing systems.

Our most current General Sales Conditions shall apply.
Please consult the most current local Product Data Sheet prior to any use.



SIKA HELLAS ABEE
15 Protomagias str.,
GR 145 68, Kryoneri
Attica, Greece

Contact
Phone: +30 2108 160 600
E-mail: info@gr.sika.com
www.sika.gr



Technical Support
801 - 700 - 7452

BUILDING TRUST

